



## Service Training of 46" PTV





# PDP Whole Components



## •MODULE

There are **1** pc. **panel** and **10** pc.s **PCB** including **2** pc.s **X/Y Sustainer board**、**4** pc.s **X/Y extension board**、**2** pc.s **W PCB**、**1** pc. **DIF** and **1** pc. **Power board in the Module.**

## •SET

There are **1** pc. Surface Filter and 9 pc.s PCBs including 1 pc. Audio board、1 pc. VIF board、1 pc. Power Line Filter、1 pc. Keypad board、1 pc. Receiver board、2 pc.s L/R Speakers and 1 pc. Video board ,1 pc. Tuner board in the SET.



Displaying your vision!



# Easy maintenance of Plasma Display

## Parts position

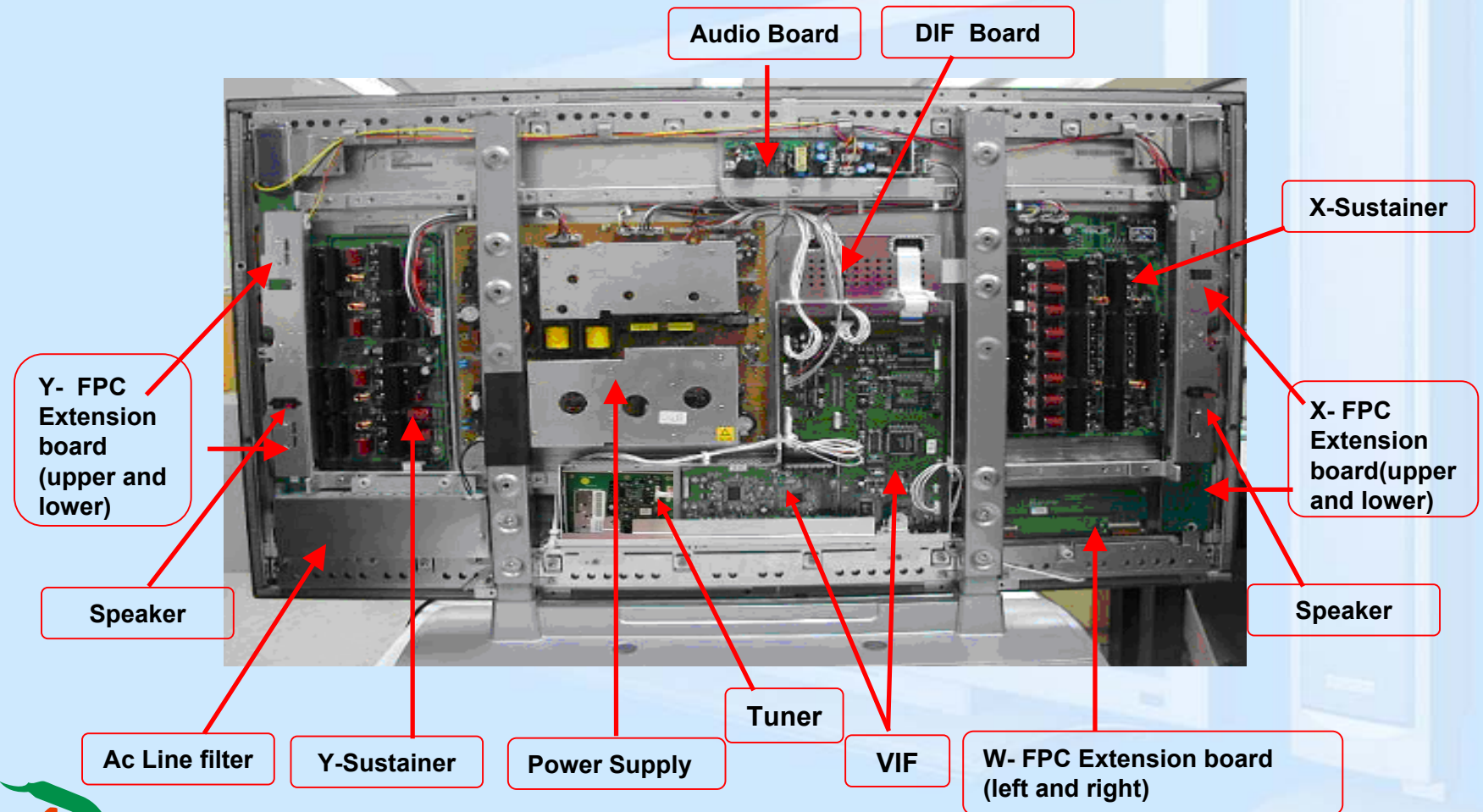



# Easy maintenance of Plasma Display

## Block diagram of system

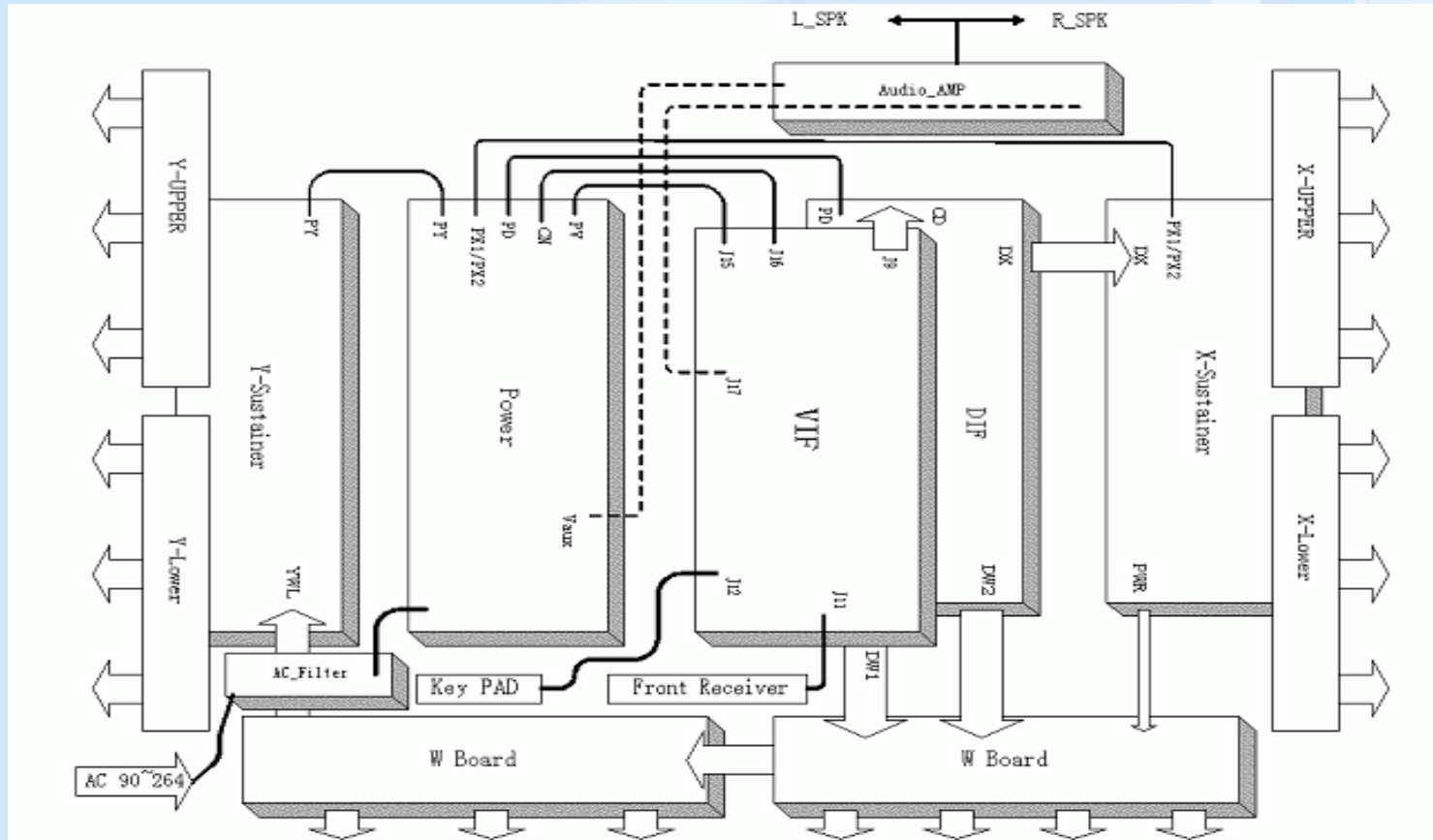



## Easy maintenance of Plasma Display



### PCB function

1. Power : (1). Input voltage: AC 110V~240V 、 47Hz~63Hz.  
Input range: 90V(Min)~265V(Max) auto regulation.  
(2). To provide power for PCBs.
2. VIF(Video InterFace) : To converter TV signals, S signals 、 AV signals 、 PC signals and D-SUB signals to digital ones and to transmit to DIF.
3. DIF(Digital InterFace) : Dealing with the digital signal for output to panel.
4. X-Sustainer / Y-Sustainer : (1). Receiving the signals from DIF and high voltage supply.  
(2). Output scanning waveform for Module.
5. X / Y-FPC extension board : Receive signal from X / Y sustainer, output horizontal scanning waveform to the panel.
6. W-COF extension board : Output addressing signals.
7. Audio Board : Amplifying the audio signal to the internal or external speakers of which selected.
8. TV tuner board : To convert TV RF signal to video and audio signal to VIF board.  
Audio output to the Audio board.



## Easy maintenance of Plasma Display



### Basic operation of Plasma Display

1. After turning on power switch, power board sends  $V_{sby} +5V$  Volt to Micro Processor IC waiting for ON signals from Key Switch or Remote Receiver.
2. When the ON signal from Key Switch or Remote Receiver is detected , Micro Processor will send ON Control signals to Power. Then Power sends volts( $V_s$  、  $V_{xg}$  、  $V_w$  、  $V_f$  、  $V_{dd}$  、  $V_{cc}$  and  $+9V$ )to PCBs working. This time VIF will send signals to display back light 、 OSD on the panel and start to search available signal sources. If the audio signals input , them will be amplified by Audio AMP and transmitted to Speakers.
3. If some abnormal signals are detected ( for example:over volts 、 over current 、 over temperature and under volts ) , the system will be shut down by Power off.



# VIF Board



## VIF System Structure

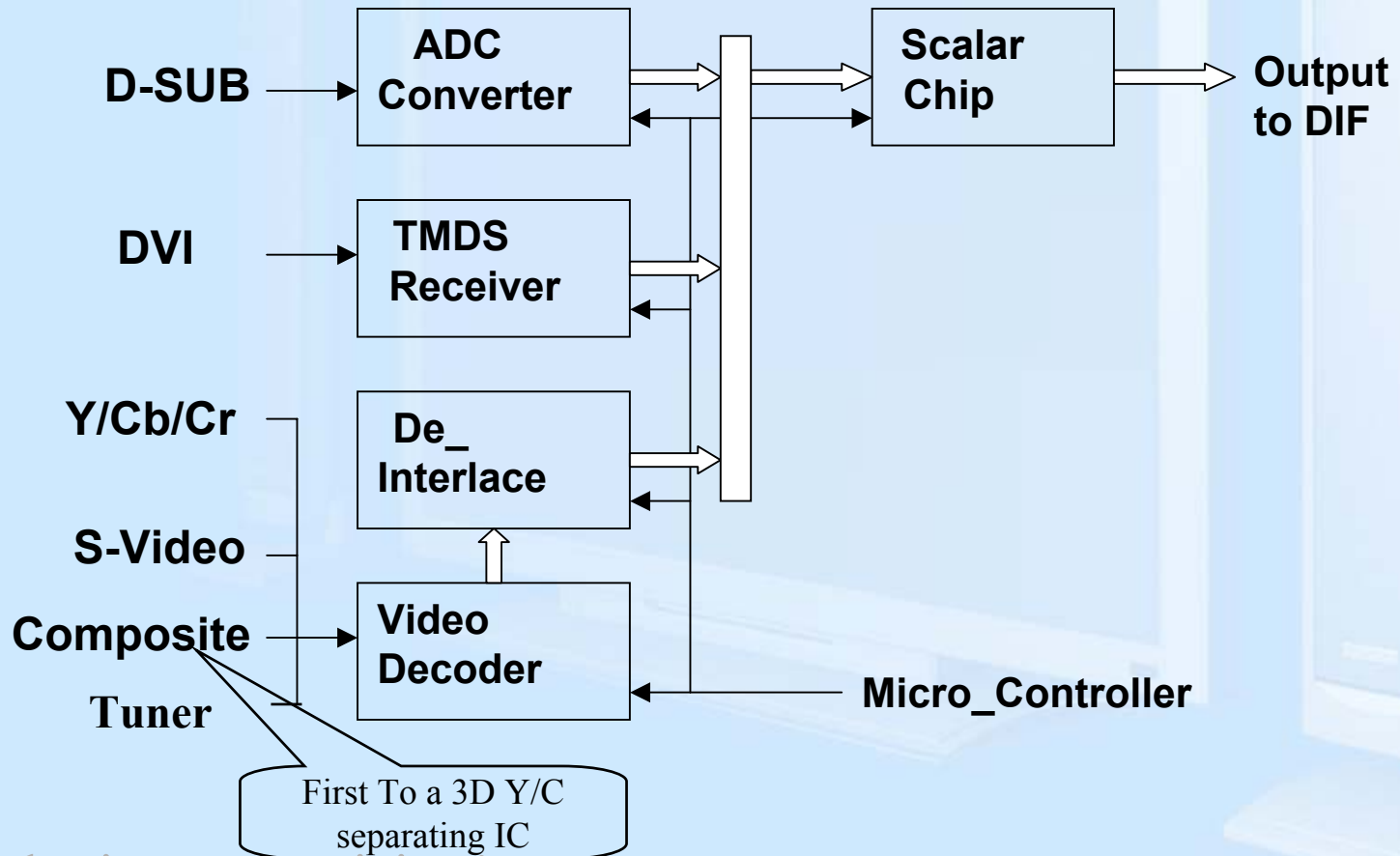

Displaying your vision!



## VIF System Block Diagram

### ADC Converter : *AD9888 KS*

The AD9888 is a complete 8 bit , 205 MSPS monolithic analog interface optimized for capturing RGB graphics signals. Its 205 MSPS encode rate capability and full-power analog bandwidth of 500 MHz supports resolutions up to UXGA(1600 x1200 @ 75 Hz).

### TMDS Receiver: *SIL151ACT100*

The Sil153BCT100 receiver uses Panel Link Digital technology to support high resolution displays up to SXGA(25MHz~112MHz) . The Sil153B receiver supports up to true color panels (24 bit/pixel, 16.7M colors) in 1 or 2 pixels/clock mode. In addition , the receiver data output is time staggered to reduce ground bounce that affects EMI.



# VIF System Block Diagram

## VIDEO Decoder: SAA7118E

The SAA7118E decoder is a ADC, too. But it can deal with the ordinary TV signals. The SAA7118E can be input Composite 、 S-video 、 Component signals and its outputs are digital Y(Luminance) , C(Chromaticity) signals. And it also can adjust brightness , contrast , saturation , hue .

## De-interlace: SIL504CM208

The Sil504 transfer interlacing signals into progressive signals. The advantage of progressive signals is that the scanning rate doubling to let the screen more stable and non-flickering. Besides, the sources of input may have 24 Or 30 or 25 frames per sec, so the de-interlaced chip shall tell from the differences and processing the signals. The basic function of de-interlaced IC is to combine the odd and even sub-frames to a frame , and the processing needs a memory IC(SDRAM) to store these signals for processing . For the improving the quality of image sake , more and more TVs or DVD players all have the functions of progressive scanning.



Displaying your vision!



# VIF System Block Diagram

## Image Processor Chip: *PW171-20U(system on chip)*

Image Processor chip: *PW171-20U(system on chip)*

### ◎ Scaling function :

The Image scalars provide high quality up and down image scaling . For the applications of VIF , the input signals could be VGA , SVGA , XGA formats , and its output fixed at 852 x 480 @60 HZ . For example , SVGA format:800 x 600 @75Hz , first scaling down : Horizontal 800→640 、 Vertical 600→480 , 75 frames / sec after frame rate conversion become 60 frames per sec. Then scaling up 640→852 , to accomplish the scaling function.

### ◎ Micro Processor Function :

This chip includes microprocessor(on-chip 80x86) ; selectable function and I/O interface control . With 3 groups of 8-bit programmable I/O , 1 group of RS-232 communication port , IR decoder ,timer and a PWM generator

### ◎ OSD Function :

The on-screen-display(OSD) can be used for startup screens , menus , and scribble functions



Displaying your vision!



# DIF Board



## DIF Structure

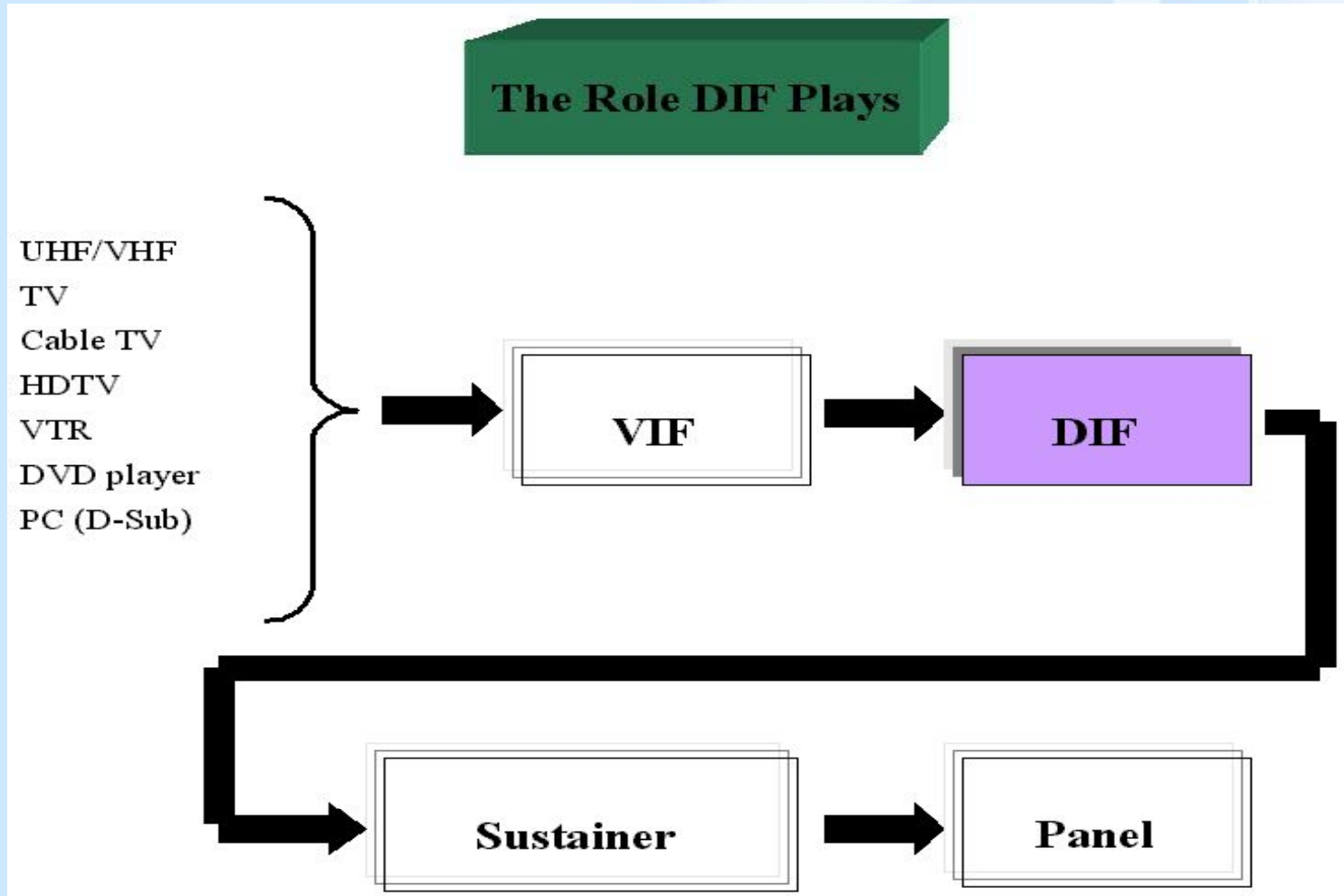

Displaying your vision!



## Three Functions of DIF :

### **(1)Image Signals Processing**

Transfer image signal into R、G、B signal respectively and according to the characteristic of a frame needed to process and adjust the signal.

### **(2)Waveform Controlling**

This function is accomplished by IC106, it generate the controlling waveform signals of X,Y sustainer

### **(3)Power Controlling**

The functions of APC (auto power control) are important to panel ; if APC were abnormal, it may cause power failure or even panel broken



Displaying your vision!



# APC Function

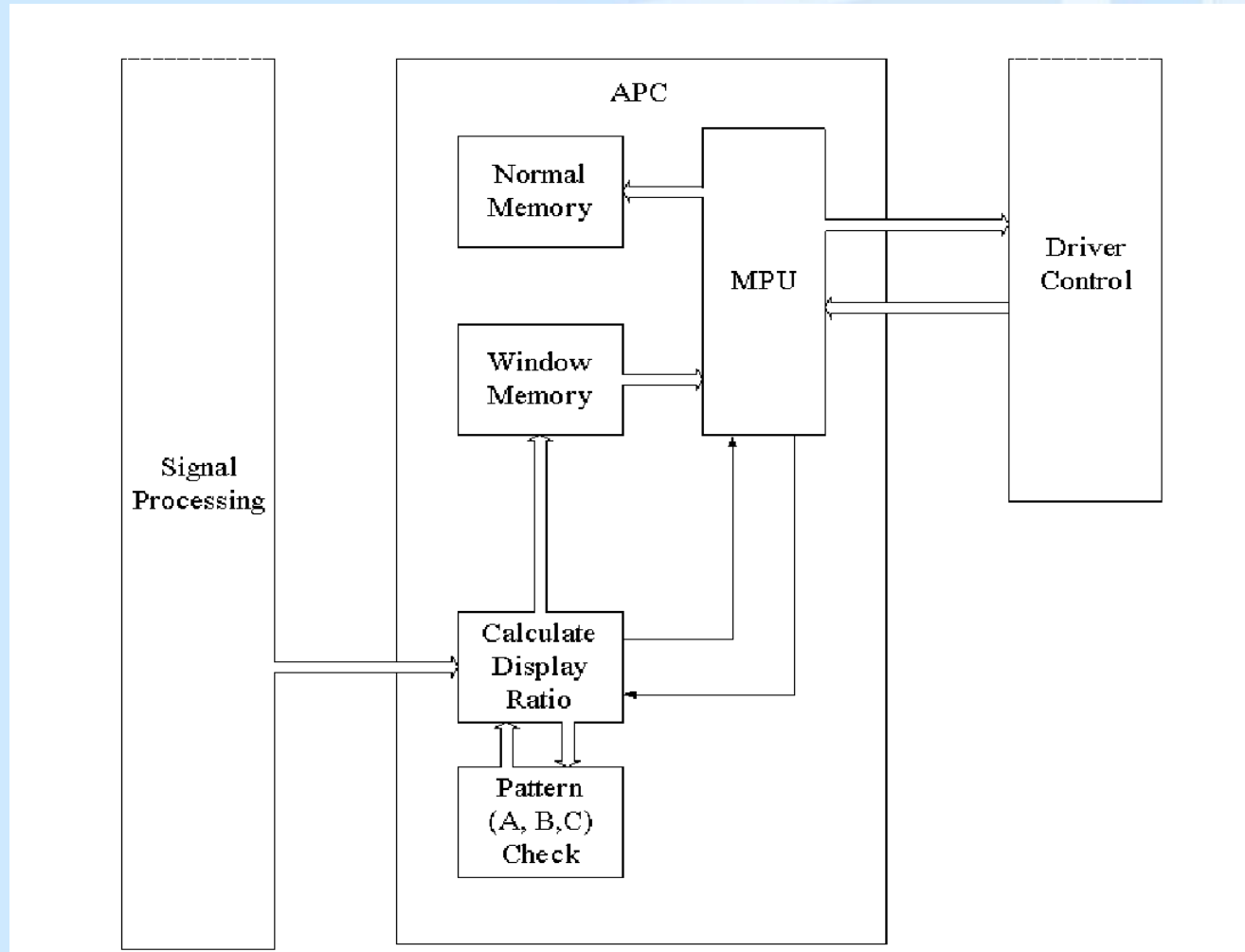

Displaying your vision!



# APC Function

After image data is transmitted to APC by signals processing unit , the Calculate Display Ratio begins to calculate the ratio of pattern. After checking and calculating pattern(A ,B , C) , the numbers of pattern , then sending the data of display and switching count to the window memory . .

The APC is performing mathematical calculations , by reducing the sustain frequency and closing some sub-fields to accomplish. There is reference for judgment. The relative parameters has been tested by experiments to determine, so if the parameters of APC are not the optimal parameter , it may cause panel broken , scan IC burned , power supply failure. ◦

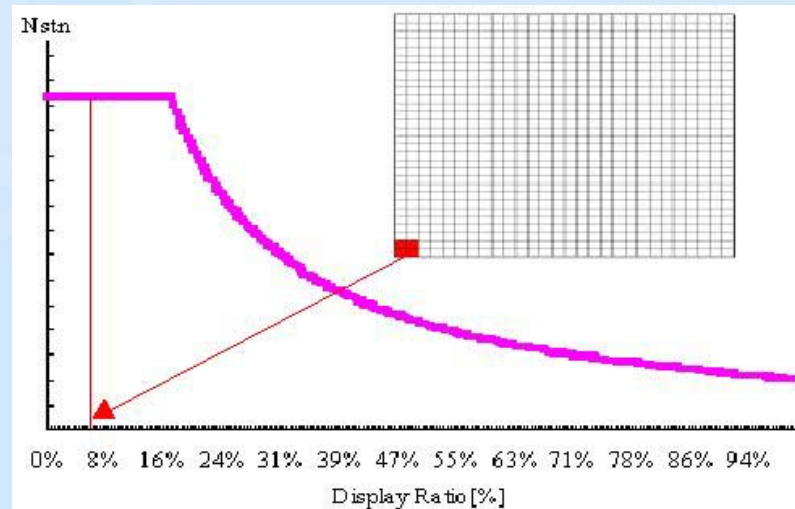

Displaying your vision!

# Power Board



## Power Board Layout

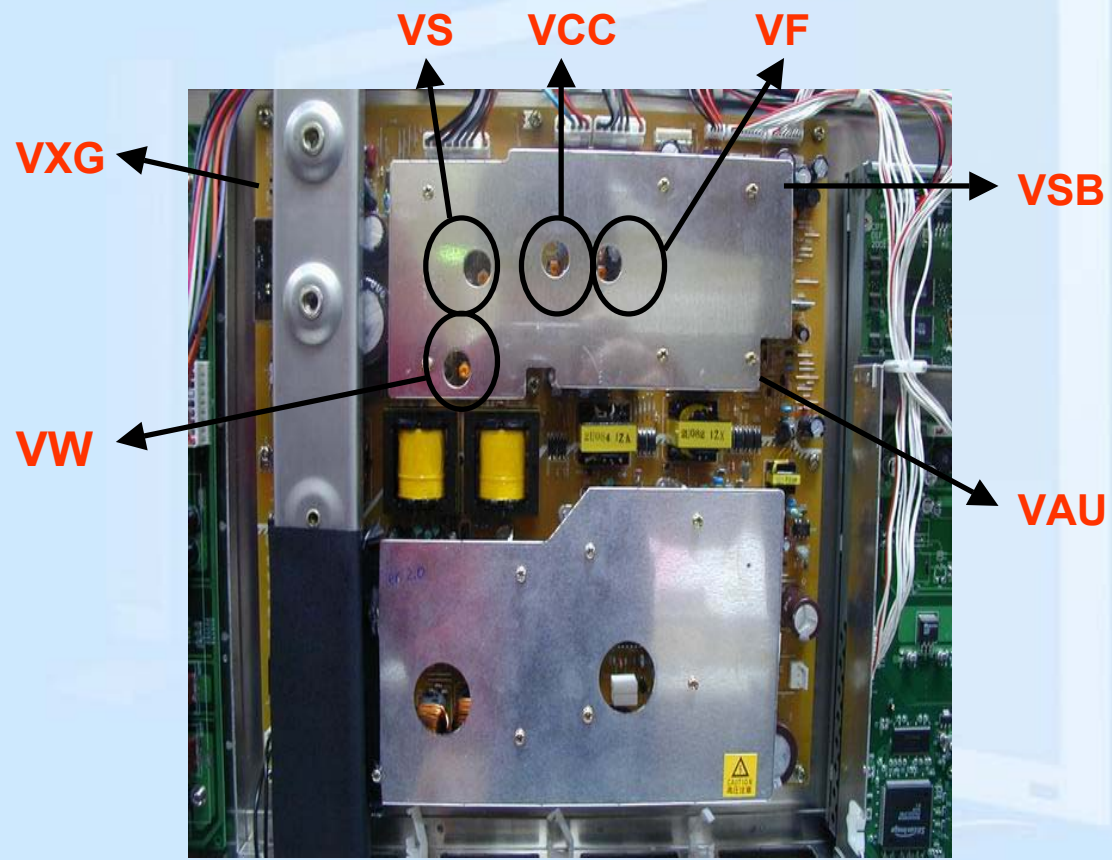

**Volts settings position**

# Power Output Spec.



Name	Output	Max Load	Peak load
Vsb	5V	1.0A	
Vdd	5V	2.0A	
Vcc	5V	3.0A	
Vau	9V	2.0A	
Vfan	12V	0.5A	cancelled
Vf	15V	0.6A	
Vs	170V	290W	50A
Vw	65V	80W	6A
Vxg	-160V	0.1A	1A
Vaux	380V	65W	

# X Sustainer



## X - Sustainer Layout

J3: W - Vw 65V input

J1:X - input

PX2:VXG,VCC  
input

PX1:VF,VW,VS  
input

J302:X - L output

J301:X -U output



Displaying your vision!



## X – Sustainer Power Spec.

Input item	Input volt(VDC)	Input current(mA)	Remark
Vcc	5	240	
Vf	15	70 (Full white)	Normal range:40~150mA
Vs	170	1.2A	Normal range:1.0~1.5A
Vxg	-160	40	
Vw	65	40	
Vs	170	1.2A	Normal range:1.0~1.5A
Vxg	-160	40	
Vw	65	40	



Displaying your vision!



## X – Sustainer CKT instruction

We have 2 sorts of low – volt system : To provide 5V and 15V for driving waveform.

65V : The volt of X -  $V_{xe}(V_w)$  is 65V. And there are 2 sets CKT in X : one is 65V for +NAMARI ; the other is 65V for W – COF. The 65V in Y –  $V_{ysc}$  is to produce 35V for Bulk during addressing period.

High volts are 170V and -160V for PDP driving volts.



# Y Sustainer



## Y – Sustainer Lay out

J302:Y - output connects to Y - FPC

J301:Y - output connects to Y - FPC

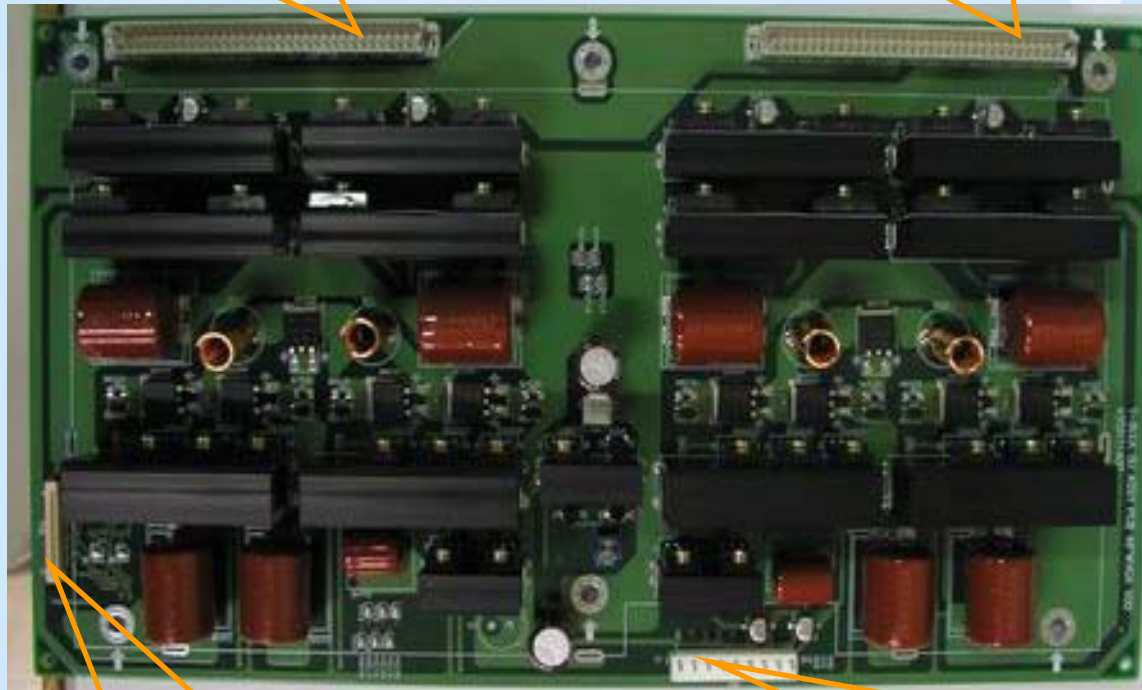

J3:To input W – signals to 20PIN

J1:Y – input power :  
Vcc , Vf , Vs , Vysc , Vw



Displaying your vision!



## Y – Sustainer Power Spec.

Input Item	Input Volts (VDC)	Input Current (mA)	Remark
<b>Vcc</b>	5	240	
<b>Vf</b>	15	70 (Full White)	Normal range:40~150mA
<b>Vs</b>	170	1.2A	Normal range:1.0~1.5A
<b>Vysc</b>	65	8	
<b>Vw</b>	65	40	



Displaying your vision!



## Y – Sustainer CKT instruction

**We have 2 sorts of low – volt system : To provide 5V and 15V for driving waveform.**

**65V : The 65V in Y – Vysc to produce 35V for Bulk during addressing period.**

**High volts are 170V and -160V for PDP driving volts.**



## Easy maintenance of Plasma Display



### PCB failure analysis

1. **DIF:** a. Abnormal noise on screen. b. No picture
2. **VIF:** a. Lacking color \ Bad color scale. b. No voice.  
c. No picture but with signals output \ OSD and back light.  
d. Abnormal noise on screen
3. **POWER:** No picture \ no power output.
4. **X - Sustainer:** a. No picture. b. Color not enough. c. Flash on screen.
5. **Y - Sustainer:** Darker picture with signals.  
( DIF + VIF + POW + X - Sus. = Dark picture : DIF + VIF + POW + X - Sus. OK )
6. **Audio Bard:** a. No voice. ( Make sure status: Mute / Internal, External speaker )  
b. Noise c. Input power : DC 300V ~ 380V
7. **X/Y - Sustainer:** The component working temperature is about 55°C . If the temperature rises abnormal , this may be a error point.



Displaying your vision!



# Easy maintenance of Plasma Display



## PCB failure analysis

### 8. X extension PCB fail

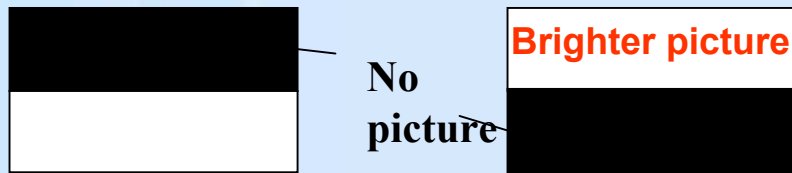

### 9. Y extension PCB fail

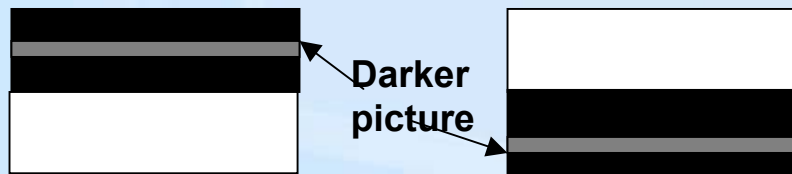



# Main Repair Flow Chart-1

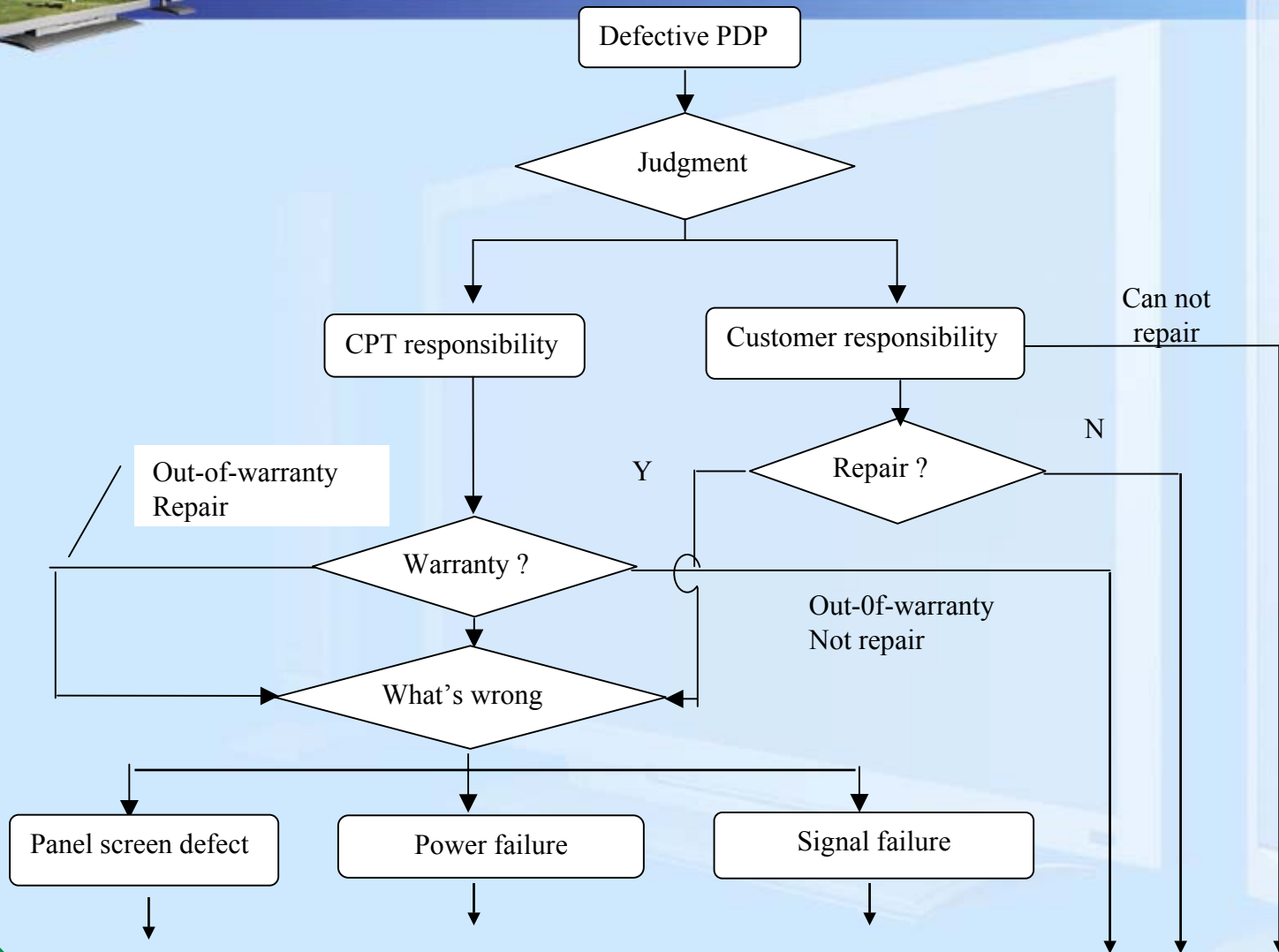





# Flow Chart:Power Failure-1

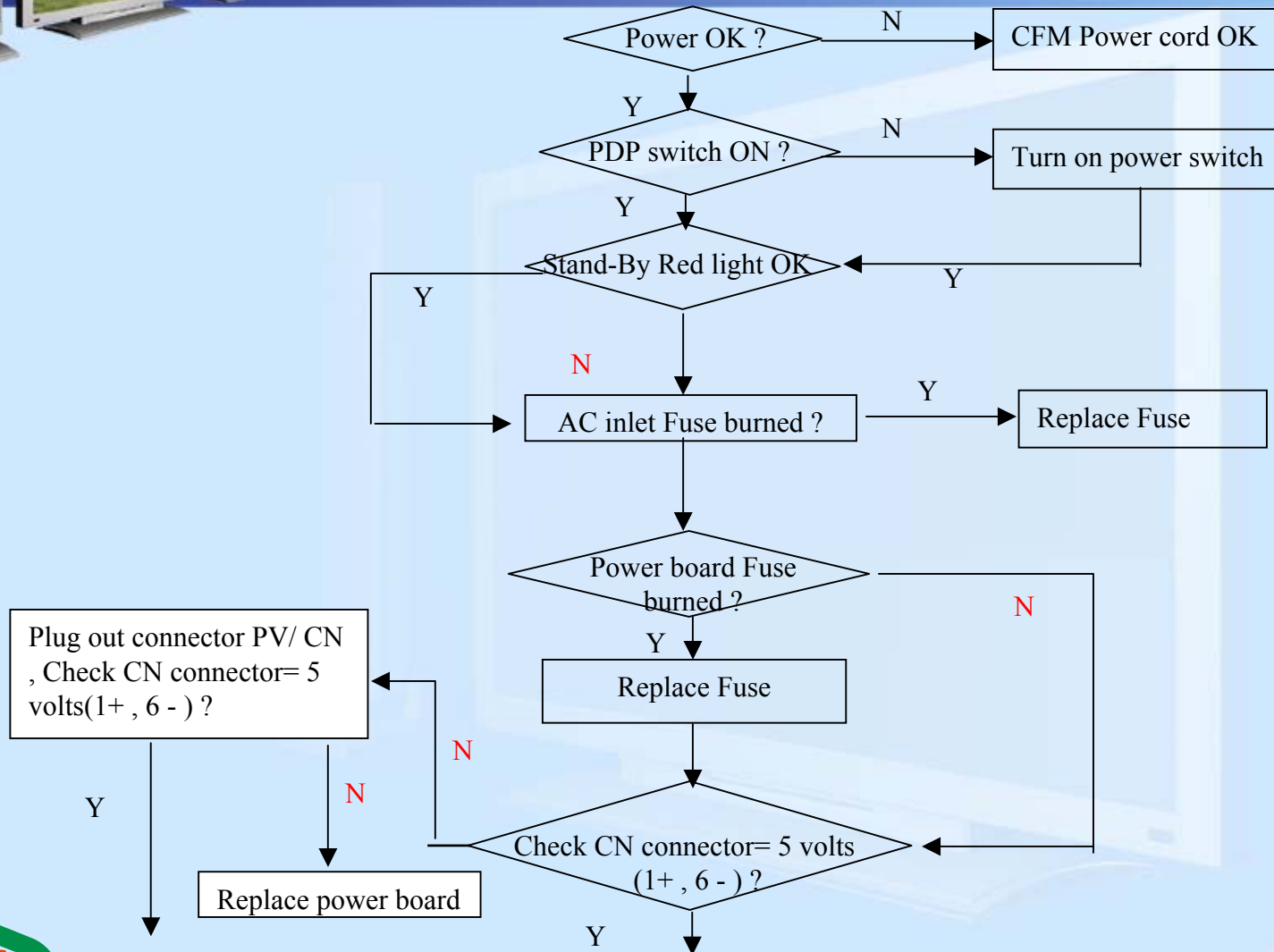

# Flow Chart: Power Failure-2

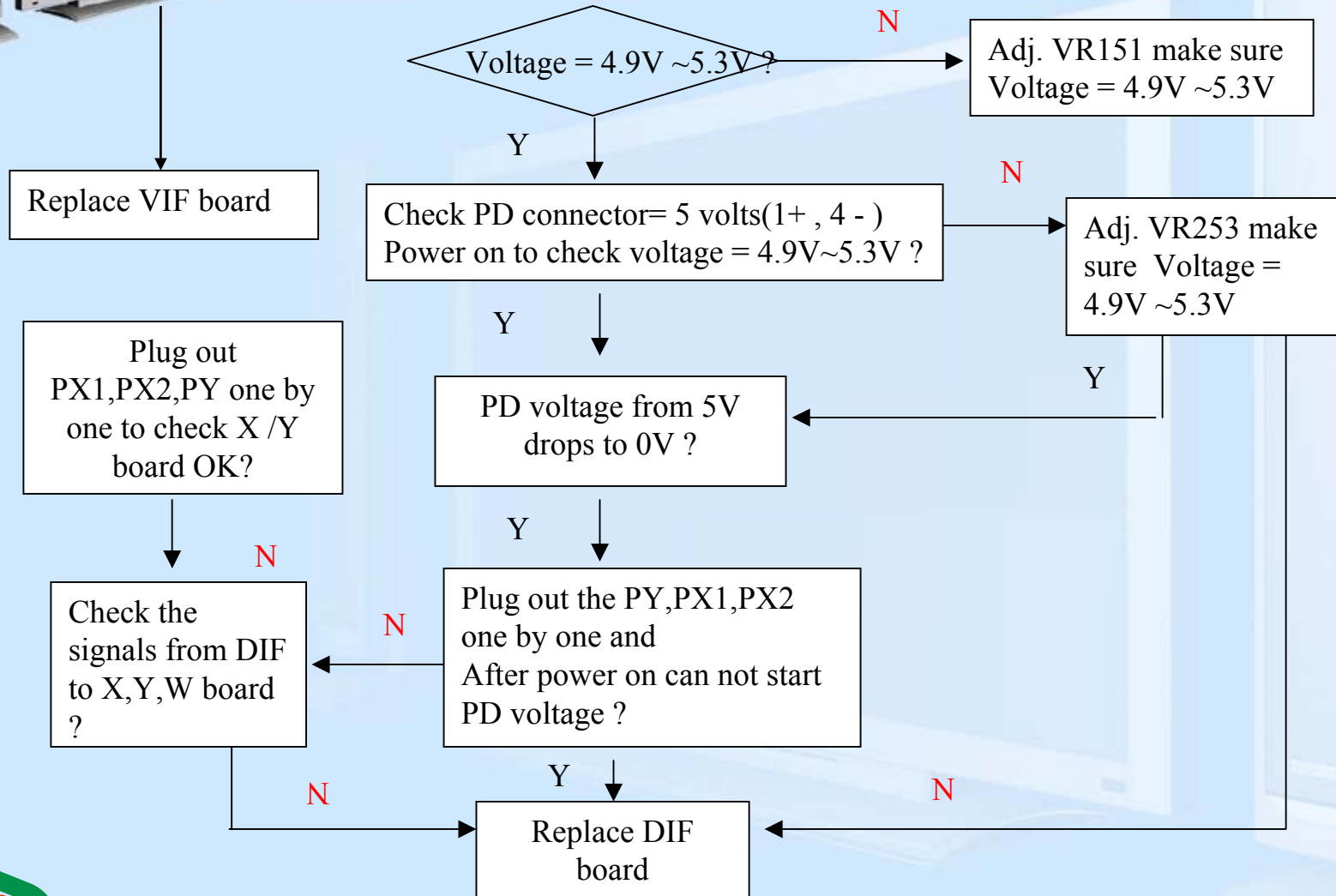



## Easy maintenance of Plasma Display

### Failure status of example

#### 1.No picture



Standby indicator(red)  
does not work.



Displaying your vision!



## Easy maintenance of Plasma Display



1. Check if the power is on.
2. Check if the fuse is burnt out.





## Easy maintenance of Plasma Display



2. Power is on but no picture.



The indicator worked after starting up.



## Easy maintenance of Plasma Display



1. Maybe VIF failed.
2. Maybe DIF failed.
3. Replace the VIF first. If it doesn't work, then replace DIF.
4. But after action as above, it still doesn't work. Replace X sustainer boards.



Displaying your vision!



## Easy maintenance of Plasma Display



### 3. Picture indistinct(IW)



Replace the Y sustainer board.



## Easy maintenance of Plasma Display



4. For the figure as below, check the connection of **X FPC**. If the connection is O.K. Replace the **X extension board**.





## Easy maintenance of Plasma Display



5. For the figure as below, check the connection of **Y FPC**. If the connection is O.K. Replace the **Y extension board**.





## Easy maintenance of Plasma Display



6. For the figure as below, check the connection between W side PCB with COF.





## Easy maintenance of Plasma Display



It's caused by bad connection of COF.





## Easy maintenance of Plasma Display



7. There is something wrong on the left side of the panel.





## Easy maintenance of Plasma Display



We have a bad connection.

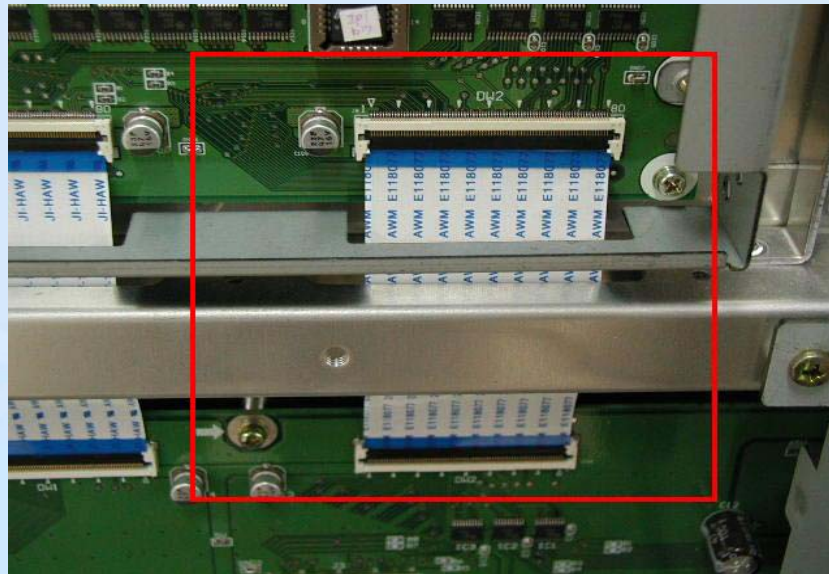



## Easy maintenance of Plasma Display



8. There is something wrong on the upper side of the panel.





## Easy maintenance of Plasma Display



We have a bad connection.

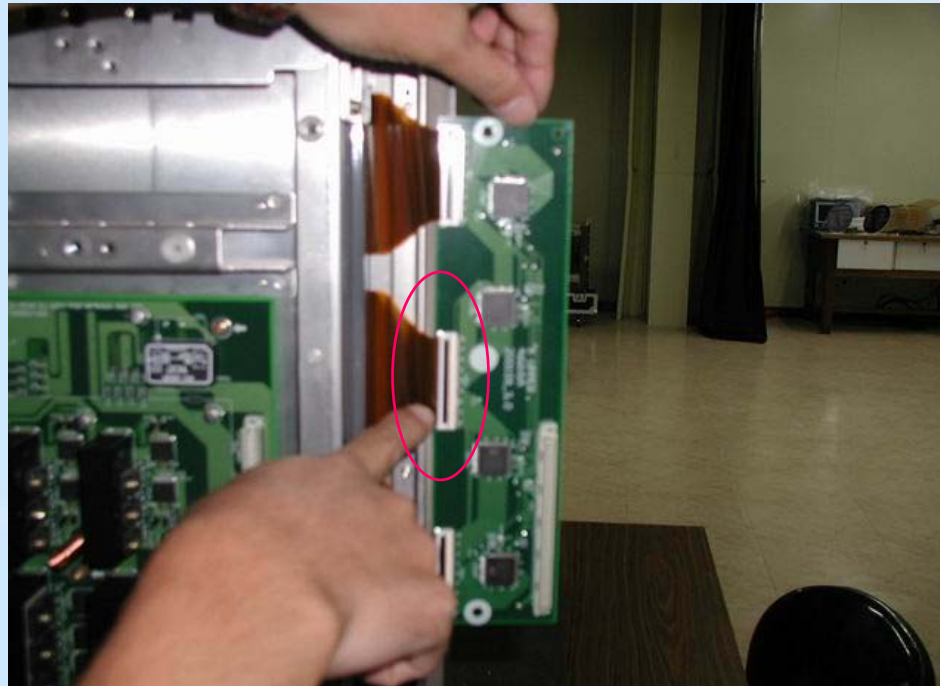



## Easy maintenance of Plasma Display



9. There is something wrong with image.



 Displaying your vision!



## Easy maintenance of Plasma Display



1. Maybe VIF failed.
2. Maybe DIF failed.
3. Replace the VIF first. If it doesn't work, then replace DIF.
4. But after action as above, it still doesn't work. Replace X sustainer boards.



Displaying your vision!



## Easy maintenance of Plasma Display



**10. There is a stripe on the screen.** Replace X extension board.

(But if it still does not work , then it was caused by the bus electrode problem -> panel's problem.)

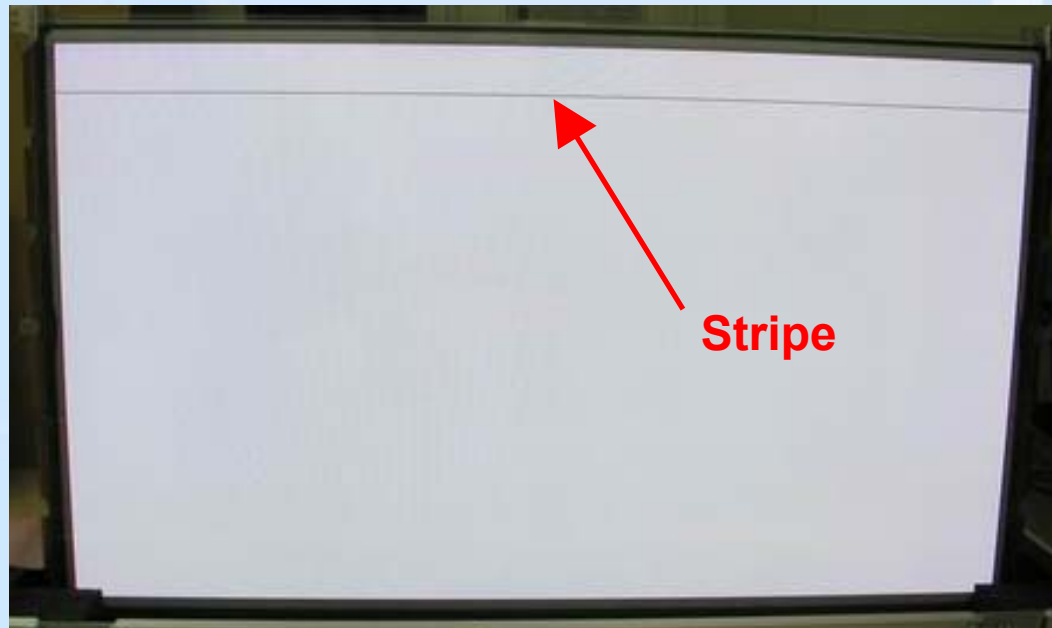



## Easy maintenance of Plasma Display



11. The status as below, replace DIF board.

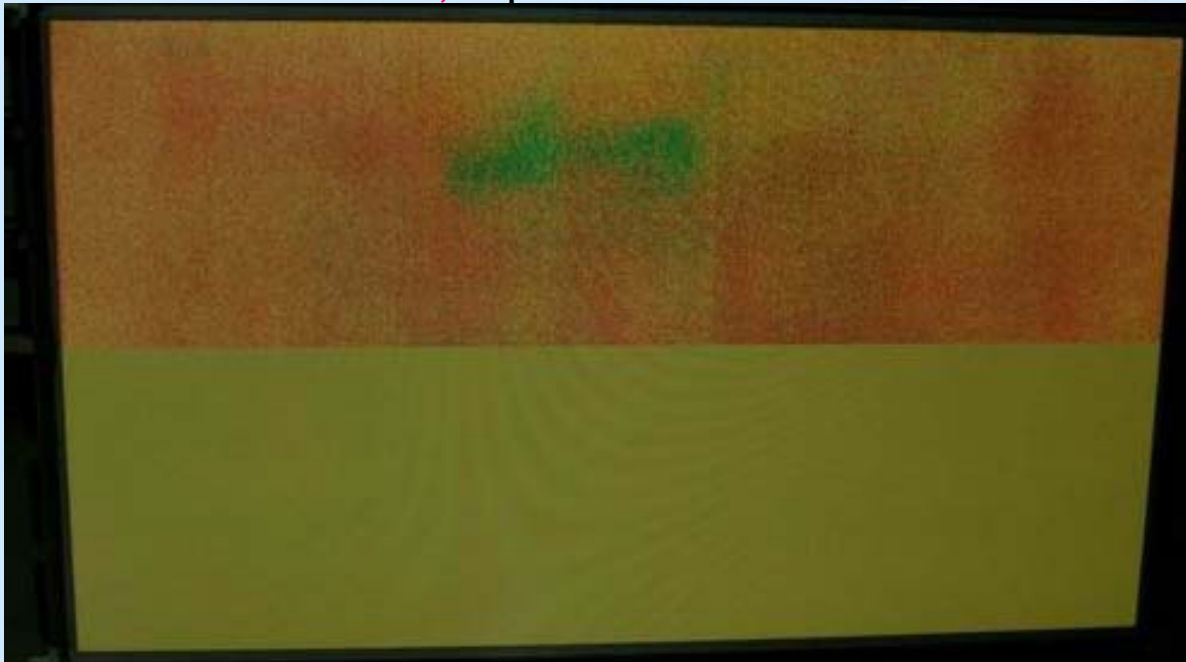

First, we thought there is something wrong in Y – FPC. But not. Why ??????

1.As general display abnormal isn't caused by failed extension board.

2.As figure above shown, we knew something wrong in upper display and high brightness. So the extension board didn't fail.

3.So we found.....



## Easy maintenance of Plasma Display



12. The status as below, replace video board.



Still in Searching.



## Easy maintenance of Plasma Display



13. This is called I.W. Adjust the  $V_s$  voltage by DVM.

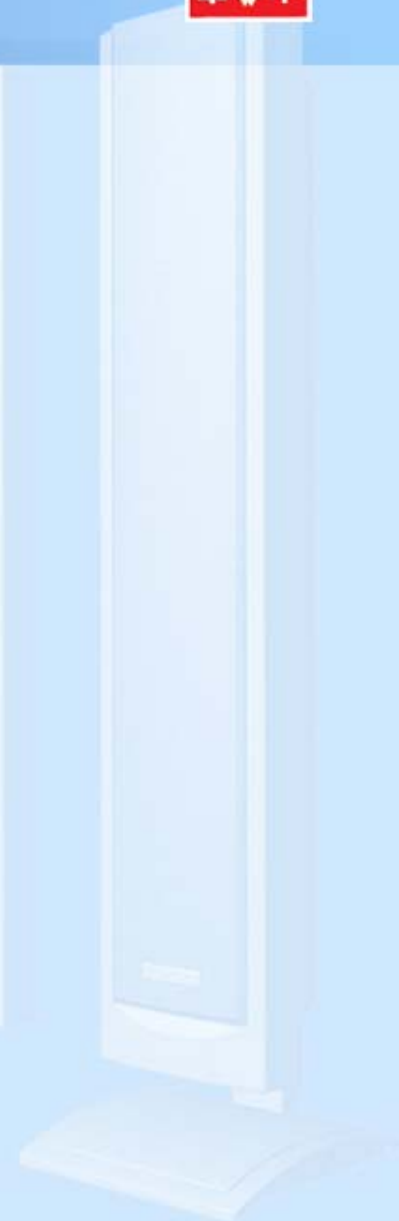



## Easy maintenance of Plasma Display

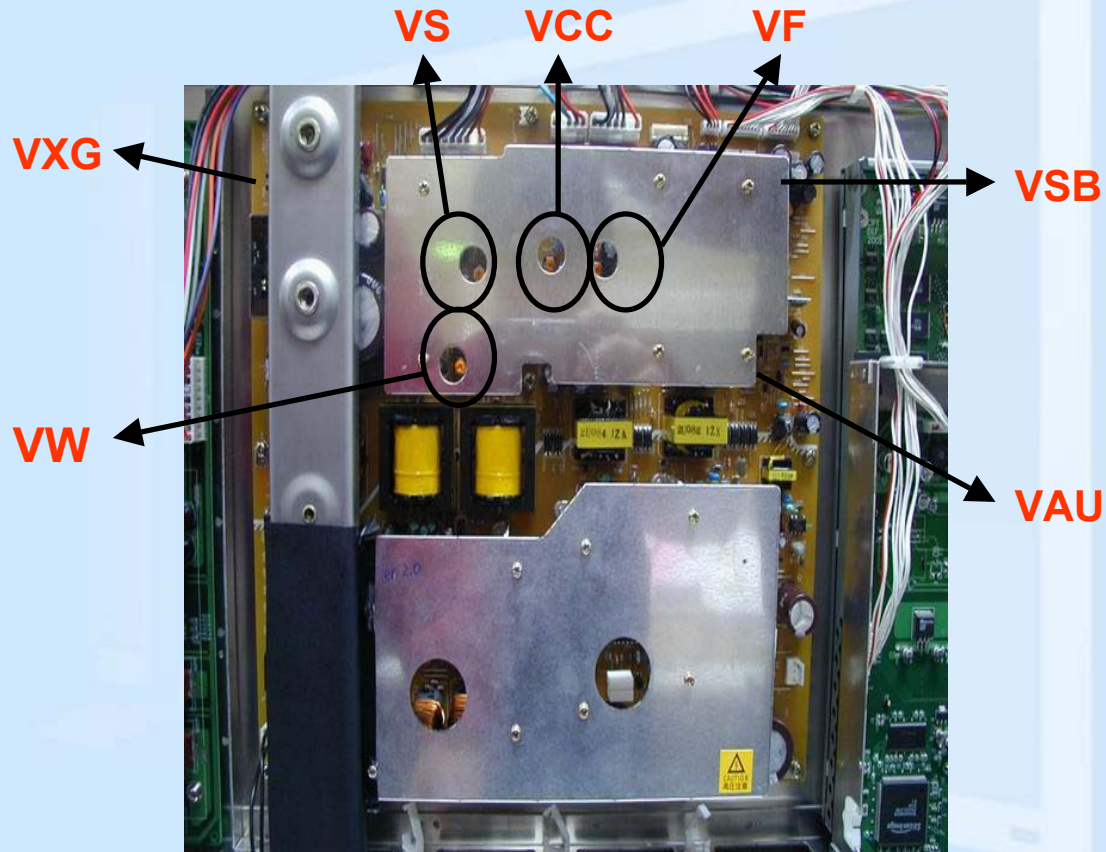

**Volts settings position**



## Easy maintenance of Plasma Display

### Power board output spec.

Name	Output	Max Load	Peak load
Vsb	5V	1.0A	
Vdd	5V	2.0A	
Vcc	5V	3.0A	
Vau	9V	2.0A	
Vfan	12V	0.5A	
Vf	15V	0.6A	
Vs	170V	290W	50A
Vw	65V	80W	6A
Vxg	-160V	0.1A	1A
Vaux	380V	65W	

**\*Vs & Vxg check the barcode label of Module**



Displaying your vision!



## Easy maintenance of Plasma Display



### 14. Vertical noise line on whole screen ?



No. This caused by Pixel Works IC on VIF. The only way is to replace VIF.



Displaying your vision!



## Easy maintenance of Plasma Display



Panel failure

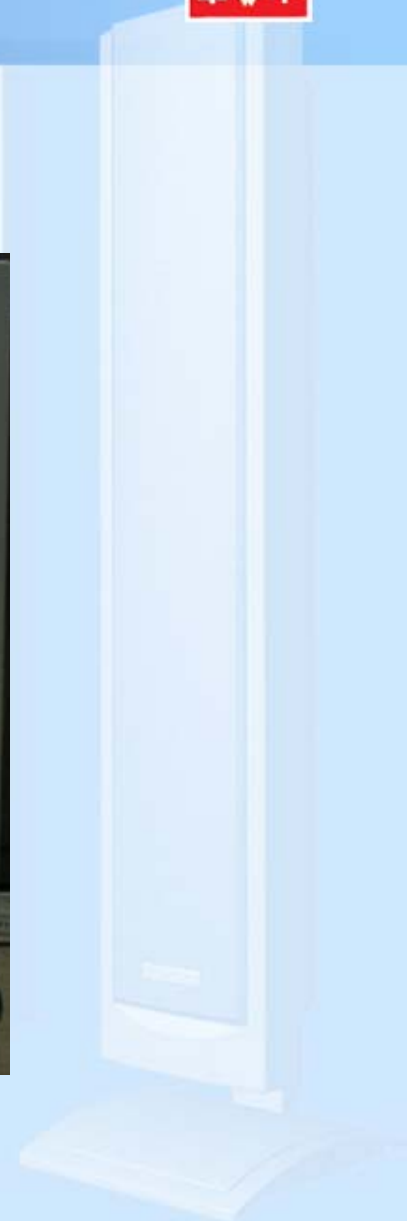



## Easy maintenance of Plasma Display



Panel W electrode line off.

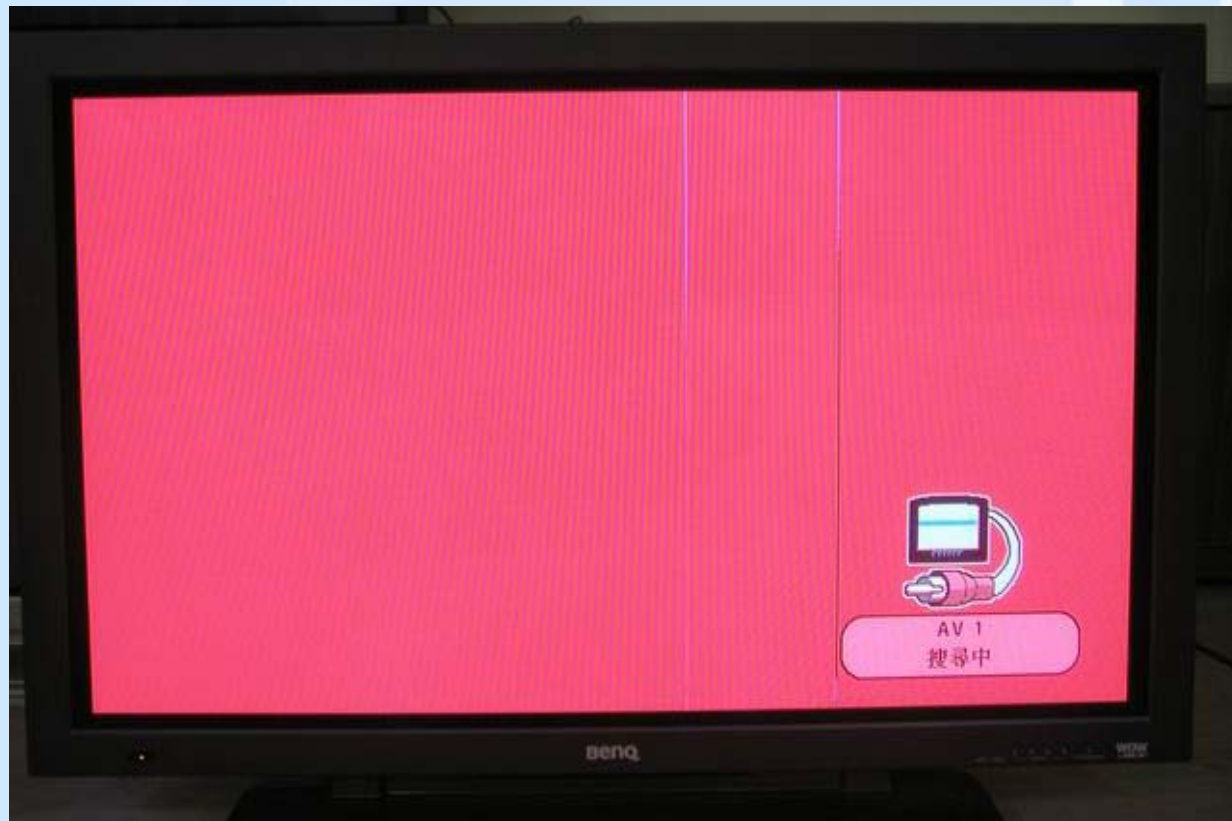



## Easy maintenance of Plasma Display



X and W electrodes line off.

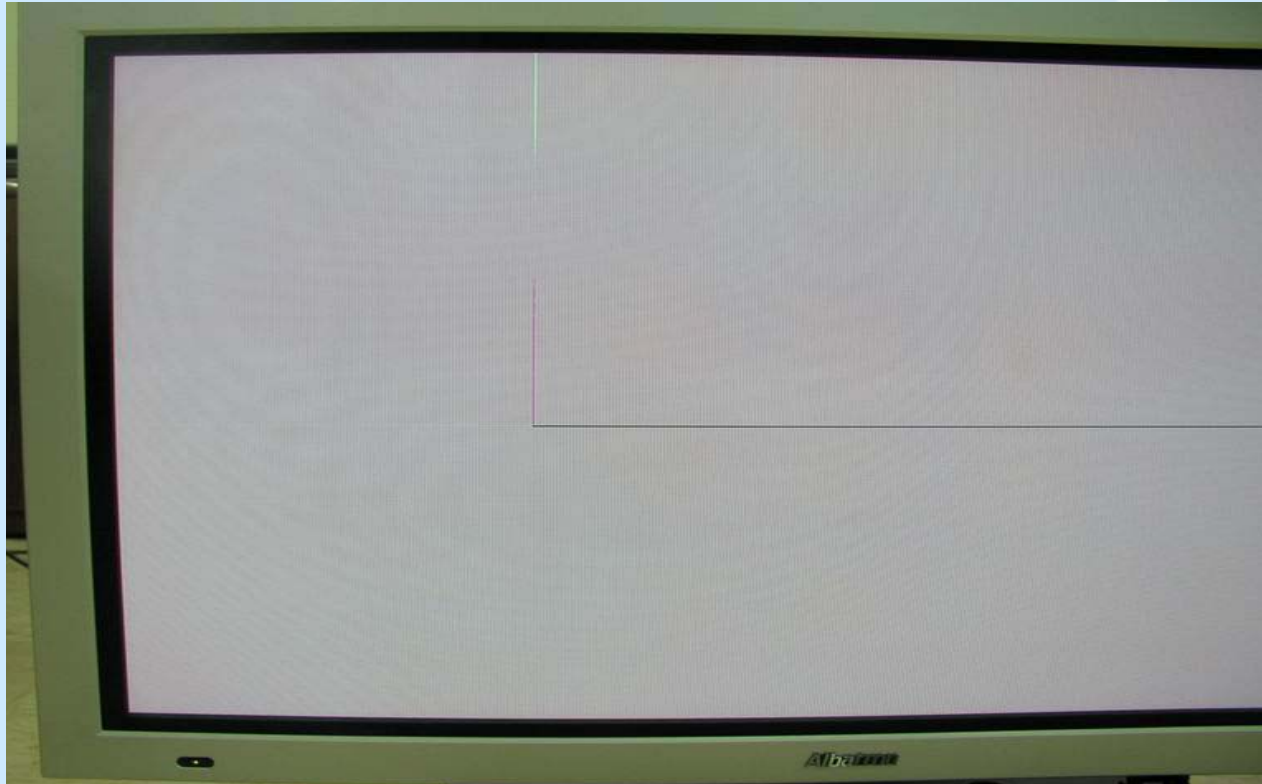

Displaying your vision!



## Easy maintenance of Plasma Display



Panel lost gas.

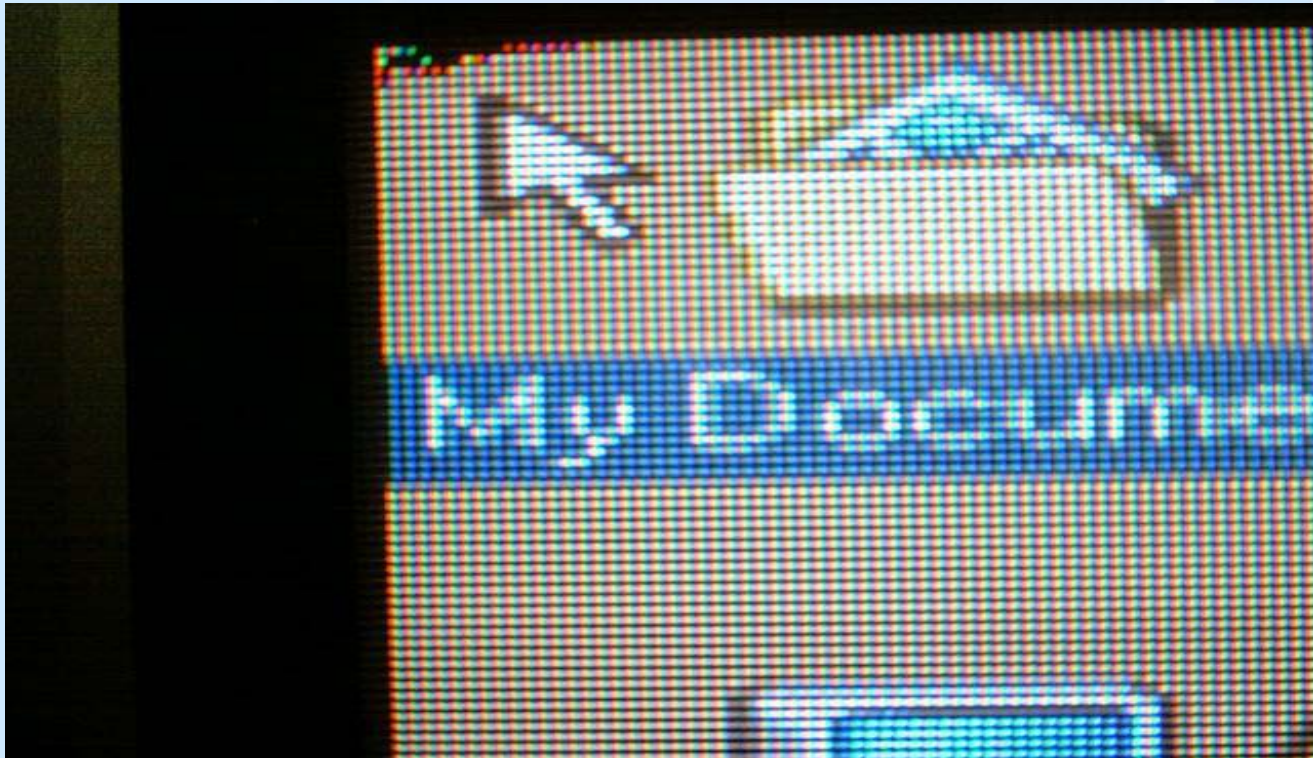

Displaying your vision!



## Easy maintenance of Plasma Display



**In principle that Panel failure can't be repaired. So what could we do? Inform the retailer fax RMA to manufacture for replacement.**



Displaying your vision!



## Easy maintenance of Plasma Display



### FAQ (Frequently Asked Questions)

#### 1. Power on the PDP set yet without any picture on the screen

- a. First check both ends of the power cable are plugged into the socket appropriately then make sure power switch being turned on, survey the red standby light is lamped, if the red standby light is not lamped it means maybe input power has some problem or the safety fuse of AC line filter is burned.
- b. If the red standby light is lamped it means input power is OK, press key to power on the PDP set if standby light turn to green successfully it means maybe there is something wrong with VIF , DIF or X,Y sustainer.

#### 2. At cable TV mode only find few television channels

In OSD manu select TV function and press enter into sub-manu, then at source mode choose CATV and execute TV Program thus all CATV channels would be found.

#### 3. How to do with image sticking?

When static image is being displayed on the screen for a long period of time may cause image



displaying your vision!



## Easy maintenance of Plasma Display



sticking on the screen.

When image sticking occurred, the only way to clear up the image sticking is press "Full White" key, using full white image to burn in the screen till image sticking disappear.

#### 4. **The signal from PC can't output to the screen**

Maybe PC input signal resolution out of PDP set accepted range, please reduce the resolution to 1024×768 or lower. If still have problem, check whether the signal line is connected properly or not.

#### 5. **The sound of external speaker is not loud enough**

Check whether the speaker cables are connected appropriately or not

Whether the impedance of external speaker match that of audio board output or not,

PDP audio output power is  $10W \times 2$ , the impedance of audio board output is about

$8\Omega$ , if the impedance of external speaker is  $16\Omega$  or higher may cause audio output

power decrease 50% or more .



Displaying your vision!



#### **6. There are some noise being found on the higher CATV channels**

Maybe the signal quality from cable station is too weak or no good, please inform the cable station to improve the signal quality.

#### **7. The signal from DVD player can't output to the screen?**

Check the signal cables from DVD output to PDP input are connected appropriately and check the type of terminal (CVBS, S-Video or the component) then check whether PDP signal input select is correct or not.

If all connection and setting are OK then maybe the problem is DVD output having some trouble or PDP set VIF board breakdown.

#### **8 How to clean the screen?**

Use a soft cotton cloth to clean the screen gently, if also unclean may wet the soft cotton cloth by alcohol and try again. (Other solutions may cause surface filter damage)